

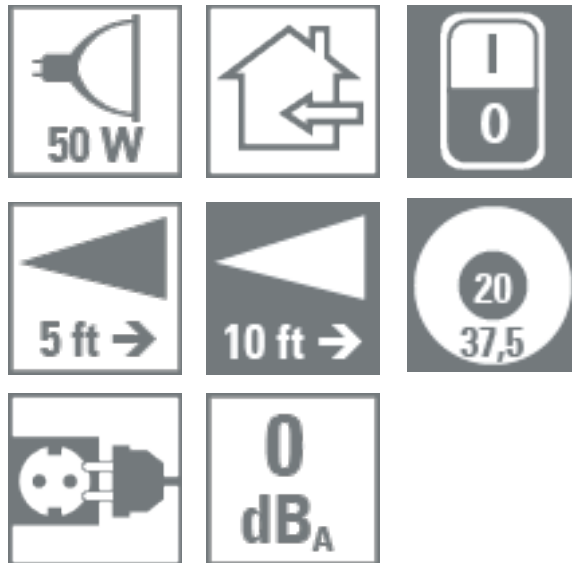

Enlightening

GOBOTOP mini 230 V PROJECTOR



SPECIFICATIONS

Item:	GoboTop Mini Projector 230 V
Body:	Heat-Resistant Plastic / Stainless Steel
Available Colours:	Black / Silver
Weight:	0.58 kg
On / Off Switch:	For Standby
Environmental Conditions:	For Dry Indoor Use Only
Ambient Temperature:	0 - 30°C
Light Source:	50 W / 12 V MR16 Halogen Lamp
Socket:	GU 5.3
Beam Angle:	24°
Recommended Projection Distance in Normal Room Light:	1.5 m / 5 ft
Recommended Projection Distance in Darkness:	3 m / 10 ft
Average Lifetime of the Lamp:	5,000 Hours
Colour Temperature:	3,200° Kelvin
Programmable Dimmer:	Can Be Activated, 6 Interval Levels Available
Gobo Size / Image Size:	Ø 37.5 mm / Ø 20.0 mm
Voltage:	220 - 240 V AC / 50 - 60 Hz
Active Power (Power Consumption):	56 W
Power Consumption In Standby:	2 W
Apparent Power:	54 VA
Efficiency:	0.99 cos. φ
Electrical Protection:	Protection Class II
Ingress Protection Rating:	IP 20
Item Number:	
Black:	09927620
Silver:	09927630

Ready for use immediately!

Unpack it, mount it and it's ready to project. The GoboTop Mini Projector, designed for close range, can be freely arranged or mounted on ceilings and walls. The motifs can be changed quickly and easily.

Light effects that attract attention:

The GoboTop Mini Projector is equipped with a programmable dimmer which enables animated effects. In six selectable interval stages the projected motif can be faded in and out.



COMPONENTS

Standard series with 50 W MR16 halogen lamp and integrated transformer. The machine is ready to plug in and run. Required accessories: glass gobo with individually designed motif.

MEASUREMENTS / DIMENSIONS

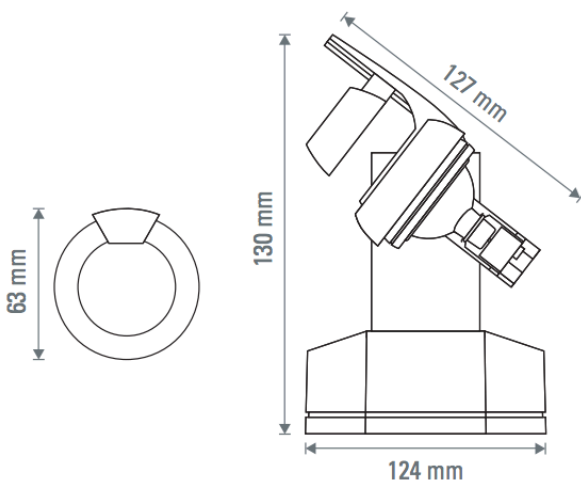

PROJECTION DIAMETER WITH INCREASING DISTANCE

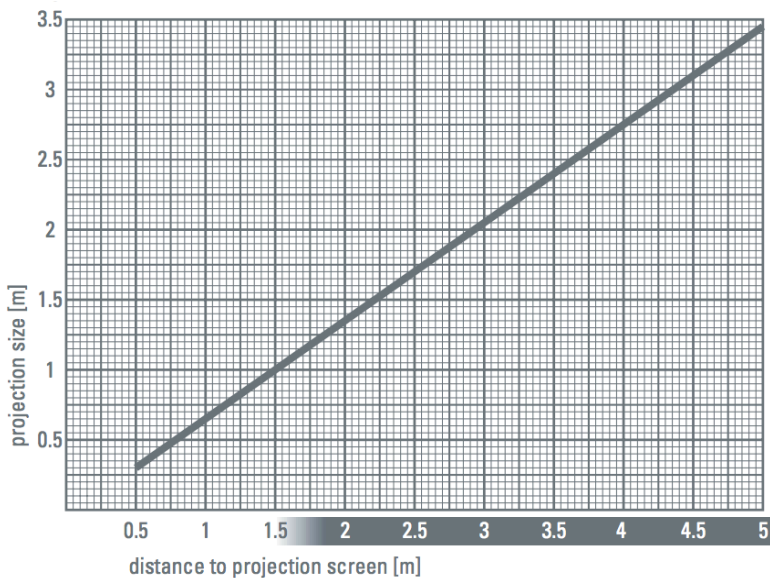

Tel: 02 9918 7225

Mob: 0407 200 080

john@enlightening.com.au

www.enlightening.com.au



We reserve the right to make technical and optical modifications. Our general terms and conditions apply.



Enlightening

GOBOTOP projector head ACCESSORY

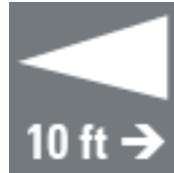

SPECIFICATIONS

The projector head can be plugged on any commercially-available 12 volt halogen system. As a result, motifs can be projected with minimal expenses where a halogen system is already installed. The mounting is achieved without tools, simply by plugging in the projector head, including the supplied multi-mirror lamp. The possibilities for use are unlimited: in table and floor lamps, on cable systems, on power rails or as a ceiling spot.



Product Number 09927520



Tel: 02 9918 7225

Mob: 0407 200 080

john@enlightening.com.au

www.enlightening.com.au

We reserve the right to make technical and optical modifications. Our general terms and conditions apply.



Enlightening

GOBOTOP ceiling spotlight ACCESSORY



SPECIFICATIONS

The Ceiling Spotlight for GoboTop can position your projected image flexibly and precisely.

Product Number 09924330



Tel: 02 9918 7225

Mob: 0407 200 080

john@enlightening.com.au

www.enlightening.com.au

We reserve the right to make technical and optical modifications. Our general terms and conditions apply.



Enlightening

GOBOTOP deflection mirror ACCESSORY



SPECIFICATIONS

The deflection mirror is plugged onto the projector head and can be removed if necessary. The light beam is deflected at a right angle so that, for example, an image can be projected onto the bottom of a showcase or shelf.



Product Number 10023520



Enlightening

Tel: 02 9918 7225

Mob: 0407 200 080

john@enlightening.com.au

www.enlightening.com.au

We reserve the right to make technical and optical modifications. Our general terms and conditions apply.

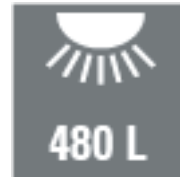

SPECIFICATIONS

Item: GoboTop 9W LED Lamp
 Voltage: 12 V AC / 50 - 60 Hz
 Power: 9 Watt
 Luminous Flux: 465 - 490 Lumens
 Rated Lifetime (L70): 35,000 Operating Hours
 Colour Temperature: 3,000° Kelvin
 Beam Angle: 25°
 Maximum Image Size: Ø 15 mm
 Dimmable To: < 20%
 Flicker - Index: 0.02
 Socket: GU 5.3

LED lamp for GoboTop.

Recommended image size of the motif is Ø 15 mm which is 5 mm smaller than standard size with MR16 halogen lamps.

Product Number 04002200



Enlightening

GOBOTOP 35W HALOGEN LAMP



SPECIFICATIONS

Item:	GoboTop 35W Lamp	MR16 halogen lamp for
Voltage:	12 V	GoboTop mini projector.
Power:	35 Watt	
Average Lifetime:	5,000 Operating Hours	
Colour Temperature:	3,200° Kelvin	
Beam Angle:	24°	
Socket:	GU 5.3	

Product Number 04001900



Enlightening

Tel: 02 9918 7225

Mob: 0407 200 080

john@enlightening.com.au

www.enlightening.com.au

We reserve the right to make technical and optical modifications. Our general terms and conditions apply.



SPECIFICATIONS

Item: GoboTop 50W Lamp MR16 halogen lamp for
Voltage: 12 V GoboTop mini projector.
Power: 50 Watt
Average Lifetime: 5,000 Operating Hours
Colour Temperature: 3,200° Kelvin
Beam Angle: 24°
Socket: GU 5.3

Product Number 04002000



Tel: 02 9918 7225
Mob: 0407 200 080

john@enlightening.com.au
www.enlightening.com.au